

## 5000 Series Low Range Pressure Transducer

- ▶ Immersible and general purpose models
- ▶ Open faced for viscous liquids
- ▶ High proof pressures

The 5000 Series features a sturdy ceramic diaphragm and precision capacitance technology to detect minute pressure variations, while withstanding large pressure spikes. The tough ceramic sensor is housed in a stainless steel case to ensure performance in the most demanding applications. Both voltage and 4-20mA outputs are available at time of order. A switch and potentiometer can be accessed for field adjustment of range with 3:1 ranging capability.



Lloyds Register



### Specifications

#### Input

<b>Pressure Range</b>	0 to 25mb to 0 to 1bar
<b>Proof Pressure</b>	2bar for ranges 200mb and below 4bar for ranges 201mb to 350mb 7bar ranges 351mb to 1bar
<b>Burst Pressure</b>	3bar for 70mb and below 4bar for 71mb to 200mb 6bar for 201mb to 350mb 10bar for bar ranges 351mb to 1bar
<b>Fatigue Life</b>	10 million FS cycles

#### Performance

<b>Long Term Stability</b>	.25% span/annum
<b>Accuracy</b>	.2% span max
<b>Thermal Error</b>	2% span max
<b>Compensated Temperatures</b>	-20°C to 60°C (-5° to 140°F)
<b>Operating Temperatures</b>	-25°C to +85°C (-15° to 185°F) Electrical Code G and L -20°C to +50°C (-5° to 120°F) Electrical Code M and 3 -40°C to +100°C (-40° to 212°F) Process media
<b>Zero Tolerance</b>	0.1% span
<b>Span Tolerance</b>	0.1% span
<b>Mounting Effects</b>	.25% span max
<b>Response Time</b>	5ms
<b>Supply Voltage Sensitivity</b>	.01% span/volt
<b>Zero Adjustment</b>	±10% (by potentiometer)
<b>Span Adjustment</b>	±10% (by potentiometer)

#### Mechanical Configuration

<b>Pressure Port</b>	(See ordering guide)
<b>*Wetted Parts</b>	S/S to UNS 31803; Inconel 625, Ceramic & Nitrile
<b>Electrical Connection</b>	(See ordering guide)
<b>Enclosure</b>	Code M IP68 Submersible Code G IP65
<b>Approvals</b>	CE, Lloyds Register Exll 1G, EEx ia IIB T4 (-20<Ta<+75°C)
<b>Weight</b>	330gms (excluding cable)

#### Individual Specifications

##### Voltage Output units

<b>Output</b>	(See ordering guide)
<b>Supply Voltage (Vs)</b>	8 to 35V Max

##### Current Output Unit

<b>Output</b>	4-20mA (2 wire)
<b>Supply Voltage (Vs)</b>	9 to 35Vdc
<b>Max. Loop Resistance</b>	(Vs-9) x 50 ohms

**How to Order**

Use the **Bold** characters from the chart below to construct a product code

**SELECT**

**Series** 5000

**Output** B - 4-20mA    C - 1-6Vdc    F - 0.1-5.1Vdc  
H - 1-5Vdc    J - 0.5-5.5Vdc    R - 0-5Vdc

**Pressure Datum** G - Gauge

**Pressure range code\*** M70 - 25 to 70mb  
N20 - 71mb to 200mb  
N35 - 201mb to 350mb  
A10 - 351mb to 1bar

**Static/Thermal Error Band** A - 0.25%/2%

**Cable Length** 000 - No cable  
001 - 1 metre  
999 - 999 metres etc

**Approvals** 3 - CE Marked  
G - ATEX approved ExII 1G  
EEx ia IIB T4 (-20< Ta <+75°)

**Electrical Connection** 3 - 1/2 - 14 NPT conduit  
G - Fixed Plug to DIN 43650, Mating Connector Supplied  
L - M12 x 1 (5 pin)  
M - Immersible Cable Assembly, IP68

**Pressure Connection** 00 - G1/4 Internal  
0F - KF25 Flange  
AK - G 1/4 External  
BK - 1/4 - 18NPT External  
KK - 7/16 - 20unf - 3A External  
MK - M14x1.5 External  
19 - Acetal nose cone

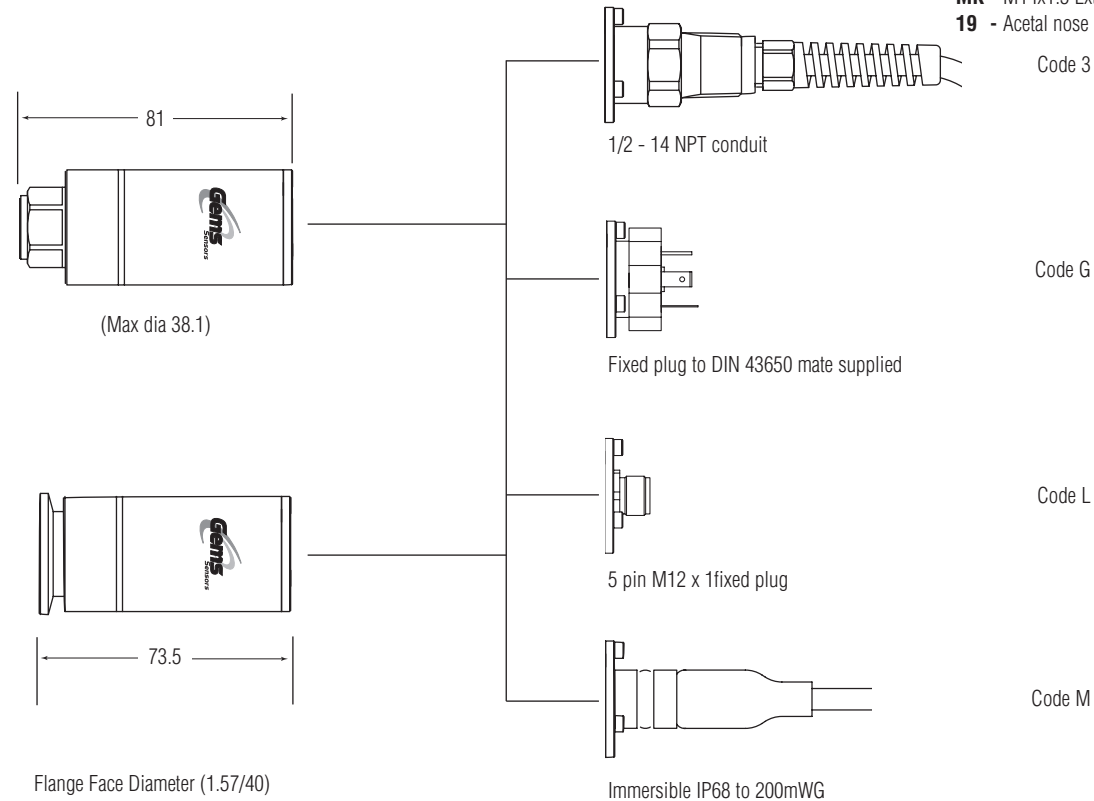

Electrical Connection	Wiring mA			Wiring Voltage			
	+	-	EARTH	+IN	OV	+OP	EARTH
G    DIN	PIN 1	2	4	1	2	3	4
M    IP68 CABLE	RED	BLUE	DRAIN	RED	WHITE	YELLOW	DRAIN
3    CONDUIT	RED	BLUE	DRAIN	RED	WHITE	YELLOW	DRAIN